

15 – 70 kW Vortex Turbine

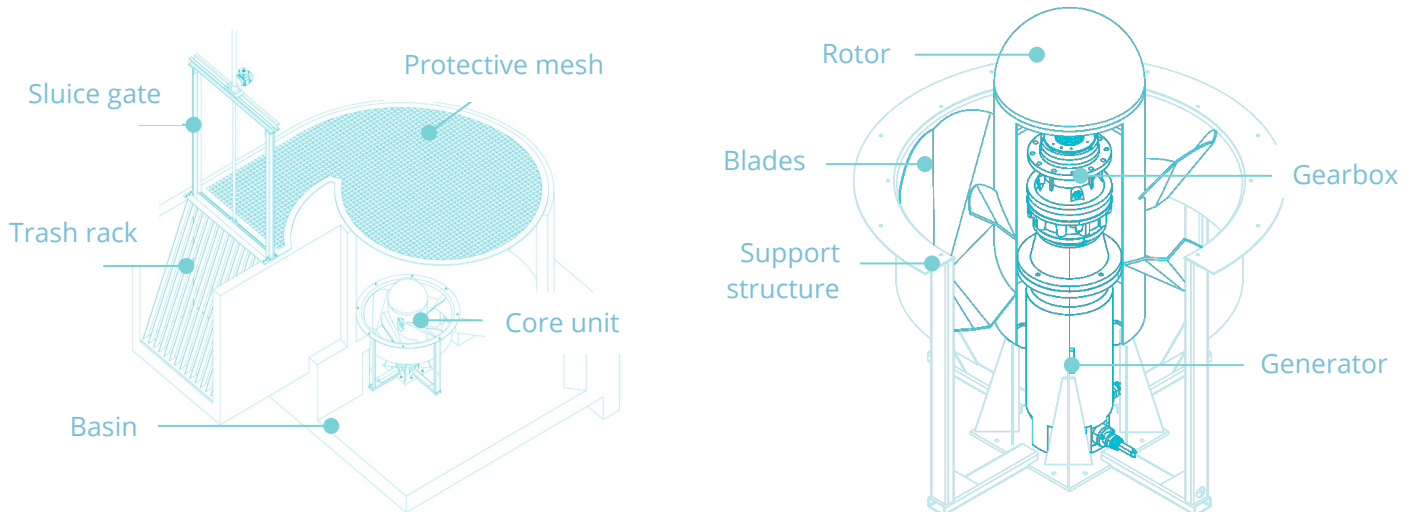

- Fish-friendly hydrodynamic rotor with flow-optimized blades and low turning speeds
- Compact low-noise submerged design.
- Core unit designed to operate for over 25 years
- Submersible gearbox and generator outfitted with Double Eagle Burgmann* mechanical face seals that can withstand any type of flood
- Secondary sealing system with multiple layers of protection against fresh and brackishwater debris and sand designed by SKF for continuous heavy-duty use in harsh environments.
- All rotor and casing parts made from stainless steel used in the food industry
- Carbon steel parts have an impact- and abrasion-resistant coating
- Equipped with maintenance-free induction generator from European manufacturers.

Vortex turbine models 5 to 70 kW	Value	Unit
Min Flow	0.7	m ³ /s
Max Flow	4	m ³ /s
Min Head	1	m
Max Head	4.4	m
Min. Speed	80	rpm
Blade tilt angle range	(-14) to 14	deg
Stainless steel type	304	-

Representative Models	15 kW	30 kW	50 kW	70 kW	Unit
Turbine hydraulic output	17.4	34.9	56.8	79.5	kW
Electrical output	15	30	50	70	kW
Maximal Energy generation per year	120,000	240,000	400,000	560,000	kWh
Nominal flow	1.5	2.2	3.1	3.8	m ³ /s
Nominal head	2	2.8	3.25	3.7	m
Impeller Diameter	1140	1200	1300	1500	mm
Rotor Height	550	580	625	730	mm
Vortex turbine core weight	275	300	360	475	kg
Generator and gearbox weight	350	600	950	1200	kg
Electrical cabinet. weight	270	330	390	480	kg

A wide range of other head and flow combinations is available (see power range graph below). All turbines can easily be transported by shipment and on a small truck. Smaller units fit on a pick-up truck.

Power Range and Maintenance

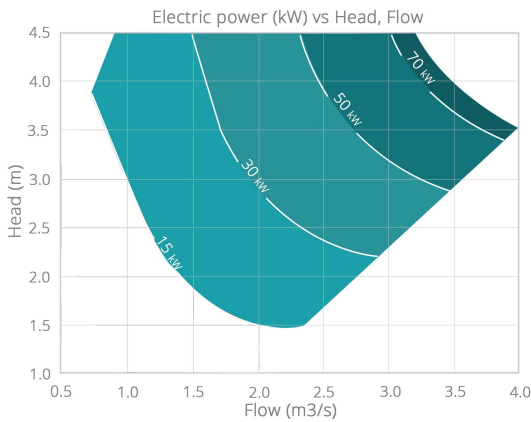

Maintenance item	Maintenance interval
Gearbox oil change	After every 6 months
Retightening all bolts	Once every year
Generator visual check	Once every year
Replacement of seals	After every 2 years
Re-greasing of gearbox bearings	After every 2 years
Electrical controls check	After every 2 years
Replacement of bearings	After every 3 years

Power Electronics



On-Grid - Cost-saving with the cleanest possible electricity

A good quality grid is available near the turbine installation & consumers. The turbine will decrease your electricity bill considerably. The backbone is an induction generator that is coupled to the grid and will provide over 90% uptime.



Basic Off-Grid - Reliable remote electricity, hydro only

A top quality micro-grid providing energy right from the water with the following features:

- Pure Sine Wave Inverter
- Controlled dump loads + Power Factor Correction (PFC) for optimal load balancing
- Starting battery for generator



Smart On/Off-Grid - Reliable electricity anywhere, combined hydro

A top quality micro-grid compatible with other power sources and energy storage. It has the same functionalities of the basic off-grid solution, with the following additional features:

- Peak consumer loads up to 3x turbine power, ensuring energy availability during peak demand
- Batteries dimensioned for peak-shaving and increased uptime till 99%
- Can be grid-connected with uninterrupted switching between on and off-grid.
- Easily integrates with other power sources like solar, wind, diesel, ...

The information in this document is subject to change without notice and should not be construed as a commitment by TURBULENT NV. Our technology was designed with the collaboration of several Universities and recognized by MIT for its promising innovations. All components are produced with partners and suppliers following ISO 9001:2015 standards.



Co-funded by the Horizon 2020 programme of the European Union

www.turbulent.be

Wijgmaalsesteenweg 6, 3012 Wilsele, Belgium